



# ***HOST LINKS™***

***Servers***

***Installation  
and  
Configuration  
on  
UNIX/Linux***

<http://www.gar.no/hostlinks/>





Microsoft, Windows, MS, MS-DOS are registered trademarks of Microsoft Corp.  
IBM and PC are registered trademarks of IBM Corp.  
UNIX is a registered trademark in the United States and other  
countries, licensed exclusively through X/Open Company, Ltd.

Any other product names are trademarks of their respective owners.

Version 6.4  
© Gallagher & Robertson as 1990-2007  
All Rights Reserved

**GALLAGHER & ROBERTSON AS**, Kongens gate 23, N- 0153 Oslo, Norway  
Tel: +47 23357800 • Fax: +47 23357801  
www: <http://www.gar.no/>  
e-mail: [support@gar.no](mailto:support@gar.no)



# Contents

---

<b>Host Links for UNIX/Linux.....</b>	<b>1</b>
Host Links product overview .....	1
Terminal environment.....	1
Server environment .....	2
Functional summary .....	3
<b>Product architecture.....</b>	<b>5</b>
Architecture diagram.....	6
<b>Packaging .....</b>	<b>7</b>
Delivery.....	7
General requirements .....	8
Memory usage .....	8
UNIX/Linux shared memory.....	8
PTYs.....	8
<b>Installation step by step.....</b>	<b>9</b>
Preparation .....	10
Copy the software to your system.....	10
Create user gar .....	10
Create directory /usr/gar.....	10
Log out, then in again as gar .....	10
Disable old Host Links releases .....	10
Installation.....	11
Run the installation script.....	11
Choosing the correct DSA transport.....	11
The licenses file.....	12
Review the release information.....	12
Set the path.....	13
Allow rlogin mode for Host Links .....	13
Install the network software .....	13
Build network configuration (dsa.cfg).....	13
Test.....	14
Configure the Host Links servers.....	14
Command line syntax.....	15
Start at system startup .....	15
Starting applications on demand .....	16

## Contents

<b>Environment.....</b>	<b>17</b>
Set Host Links profiles .....	17
Environment variables.....	17
PATH .....	17
GAR_SYSDIR .....	17
GAR_MODE .....	17
<b>Server Administration.....</b>	<b>19</b>
Gmanager .....	19
Gdir .....	22
Tools.....	23
Glicense.....	23
Gver.....	24
Gdump.....	24
<b>Host print in DSA networks .....</b>	<b>25</b>
Print to screen session .....	25
Print on separate session.....	25
Gspool .....	25
<b>Sample dsa.cfg.....</b>	<b>27</b>
<b>Appendix: Host Links Manuals.....</b>	<b>29</b>
<b>Appendix: The text library .....</b>	<b>31</b>
gcptexts - Maintain program texts.....	31
Procedure for modifying the library .....	32
<b>Appendix: Error Codes.....</b>	<b>33</b>
OSI/DSA error codes.....	33
Windows Sockets error Codes.....	45

# ***Host Links for UNIX/Linux***

---

This manual describes installation and configuration of the UNIX/Linux version of the product set.

## ***Host Links product overview***

### ***Terminal environment***

Host links products that run on UNIX or Linux servers with a terminal driven user interface include emulators and concentrators, as well as various utilities.

- **G3270** provides synchronous IBM3270 functionality. G3270 emulates IBM LU type 2, including base and extended colour together with extended highlighting.
- **Qsim** provides synchronous Questar terminal functionality. Qsim simulates all Questar models, including the DKU7007, DKU7107, DKU7105 and DKU7211 (Mono, four colour A/B and seven colour modes are supported). It also simulates the VIP7760 and the VIP7700.
- **V78sim** provides Bull VIP78xx (BDS) functionality. V78sim emulates all models of the VIP7800 family; the actual reference is the BDS7. All visual attributes including colour are supported.
- **Pthru** provides transparent VIP7800 visibility to Bull mainframes for users with asynchronous VIP7800 terminals or emulators. The terminals are used in text or forms mode.

## Server environment

Host Links products that run on UNIX, Linux or Windows servers.

- **Ggate** is a transparent gateway to the Bull native network. It avoids all need for Front-ends (MainWay/Datanet) or other gateways. It can be used to connect G&R/Glink (for Windows or Java) emulators or any of the emulators, concentrators, network printer emulators and file transfer clients/servers in the Host Links product set. It also supports third party clients using the Bull TNVIP and standard asynchronous Telnet protocols.
- **Gweb** provides a web browser interface to any host application that is otherwise accessible using the *Host Links Qsim*, *V78sim*, or *G3270* emulations.
- **Gspool** is designed to run as an unattended process and accept transparent print output from any type of host application (GCOS8, GCOS7, GCOS6, IBM) that normally sends print data to network printers (ROPs), or to a remote spooling system (DPF8-DS). On the Gspool system the print may be directed to a physical printer or to the local spooling system. Gspool operates in different modes, Connect mode, Terminal Writer mode, DPF8 mode, SNM mode, IBM mode, TN3270 mode and TN3270E mode.
- **GUFT** is an implementation of the Bull UFT file transfer protocols. These protocols enable transfer of data files between heterogeneous systems. The systems must be interconnected in a DSA/OSI network running over a private or public X25 network or over a local area network (LAN).
- **Gproxy** is a network management program used for supervision, management, load balancing and license sharing of G&R *Host Links* applications. *Gproxy* can be set up as a freestanding monitor program and/or report generator in a small network, or play a bigger role in a larger network.
- **Gsftp** is a transparent gateway between two different File Transfer protocols: FTP (RFC 959) and SFTP (the SSH File Transfer Protocol). The purpose is to present a seamless integration between the two protocols, with automatic conversion.

## ***Functional summary***

The G&R Host Links products transform any server platform into a native DSA or DSA/ISO Workstation (DIWS) node in the Bull primary network, or into a 3270 cluster within SNA. Communication between the Host Links system and the Bull systems is generally done using the Bull DSA session protocol. Communications with IBM systems is by TN3270/TN5250.

The DSA connections can be made in the traditional way using OSI-transport, which is a requirement when connecting via old-style Datanets. The Bull systems can be accessed over an X.25 WAN or Ethernet LAN through a Datanet or MainWay front-end. Alternatively access can be direct to GCOS6 using a LAN adapter or direct to GCOS7 using ISL. Access can be by an FDDI LAN direct to GCOS7 using FCP7 or direct to GCOS8 using FCP8.

The DSA connections can also be made over a TCP/IP network, using the Internet standard RFC1006 transport protocol to replace OSI-transport. MainWay front-ends with an ONP (Open Network Processor) have RFC1006 support in the standard product, allowing DSA sessions over TCP/IP into the MainWay. RFC1006 can also be installed in the FCP7 and FCP8 cards to support DSA connections direct to the hosts without passing through the front-end. The GNSP on newer GCOS8 systems accepts DSA/RFC1006 connections, as does the newer GCOS7 Diane systems. G&R Host Links systems are qualified with both.

The Ggate product may be used to off-load the DSA session protocol into gateways. By running Ggate on the system(s) with the host connections all other PCs, Macintoshes, Windows and UNIX machines in your network need only the very small and efficient Ggate protocol layer to connect over TCP/IP to a Ggate gateway with full primary network functionality. Ggate can make the host connection using OSI-transport or RFC1006. If you must use OSI-transport for the host connection, using Ggate will limit the need for OSI-stacks to the Ggate platforms.

IBM systems can also be accessed using Telnet 3270 (TN3270 or TN3270E) to connect to any TN3270⇔SNA gateway or front-end. The MainWay gateway, the TN3270 server on the Bull DPX/20 UNIX systems, the IBM TN3270 front-end and the TN3270 server for Windows are all qualified.

## **UNIX/Linux**

Bull systems can also be accessed using Telnet VIP (TNVIP). The TNVIP servers in the MainWay and in the Bull DPX/20 are both qualified. However, RFC1006 is supported in the MainWay front-ends with an ONP (Open Network Processor), and if used when communicating with G&R products it will increase throughput as compared to using TNVIP. It will also give a real, fully functional DSA or DIWS session over the TCP/IP network, as compared to the limited terminal session offered by TNVIP.

# Product architecture

---

The UNIX/Linux versions of the G&R products are built in a modular way, and designed to take advantage of the multitasking capability of the UNIX/Linux platform. Thus a single instance of a product will in general consist of three quite separate processes, communicating with each other using pipes and shared memory. In general there will be:

- A video handler; which accepts user key input and transforms it into the internal standard format. It also maps all updates of the internal screen image into the control sequences required to update the specific screen being used.
- A product; for example an emulator which accepts key input in the standard format and updates the internal screen image according to the presentation being emulated. An emulator will also send and receive data to the mainframe system using the standard interface that applies to all communications protocols.
- A line handler; which maps the standard format for communications into the specific line protocol being used.

This structure has proven itself extremely efficient and very robust. We are able to develop a video handler for a new screen type, and we know that once it works with one G&R product it will work for all. We are able to develop a new line handler and know that once it works with one product it will work with all. We are able to develop a new product using a given screen and communications protocol, and know that the product will work with all screen types we support, and with all the communications protocols we support.

Ggate, Gspool and GUFT server differ slightly from the above model, as they don't need a video handler, only a line handler.

Some of the programs in the Basic product, like Gdir and Glist, also differ slightly as they don't need a line handler, only a video handler.

# Architecture diagram

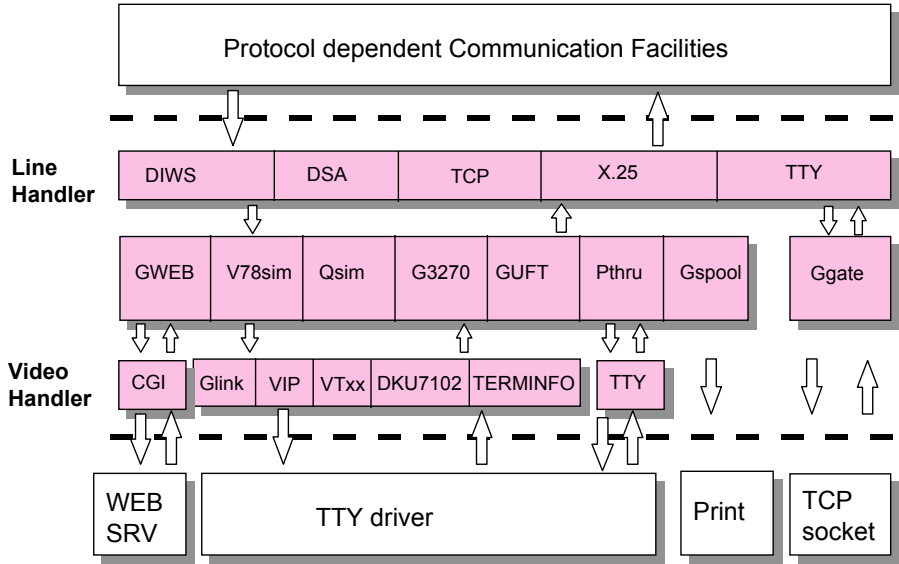

# Packaging

---

## Delivery

We deliver the software in various ways; these instructions assume you have the distribution files in a directory on your system (e.g. /tmp/hlinstal). They are only used during installation and you may remove them afterwards. You should have received these files:

install.640	Installation script
srbhl.640	Software Release Bulletin
licenses	Optional, license keys to give access to the software
unzccccoo	Unzip program
basccccoo.640	ZIP archive of basic Host Links
pppccccoo.640	One or more ZIP archives with software

**ppp** refers to the product name. **ccc** refers to the CPU family and **oo** refers to the operating system. The products and platforms supported in any release are specified in the **SRB** (Software Release Bulletin) for the release. The 640 extensions refer to the release number. Some examples of complete filenames:

ggax6412.640	Ggate for Intel x64_x86, Linux kernel 2.*, release 6.4.0
Gsp38612.640	Gspool for Intel x86, Linux kernel 2.x, release 6.4.0
gwbppca5.640	Gweb for Bull, AIX 5L for Power, release 6.4.0

These files are packaged in ZIP format archives using Info-ZIP's software, and the installation script unpacks them with the unzip program we deliver.

Info-ZIP's software (Zip,UnZip and related utilities) is free and can be obtained as source code or executables from Internet/WWW sites, including the Info-ZIP home page: <http://www.info-zip.org/>

## ***General requirements***

### ***Memory usage***

The exact amount of memory used by the different application will vary from platform to platform. Our measurements indicate that typical memory usage per session is around 250KB for a Ggate session and 500KB for an emulator.

Using the SSL feature will significantly increase the memory usage. The actual increase is platform specific but will typically be from 250KB to 500KB per session.

### ***UNIX/Linux shared memory***

Each instance of a video handler needs one shared memory segment. Most UNIX/Linux platforms default to 50 or 100 of these. Please refer to your UNIX/Linux documentation on how to increase the number of shared memory segments.

### ***PTYs***

If your terminal or PC logs in to the UNIX/Linux system over TCP/IP and Telnet or Rlogin, then you may also be limited by the number of so-called PTYs (pseudo-TTYs) you can have on the system. Please refer to your UNIX/Linux documentation to see if it's possible to configure more PTYs and how to do it.

# Installation step by step

---

The default system directory for Gallagher & Robertson products is:

```
UNIX/Linux /usr/gar
```

Many of the Host Links programs will look for text files, configuration files and macro files etc. in the Host Links system directory. The installation script will give you a choice to select another directory as the default system directory, but you should note that if you do that, you must define a `GAR_SYSDIR` environment variable that points all Host Links users to this directory.

For a new installation we strongly recommend that you create a new UNIX/Linux user id and group id for Host Links. An obvious choice of names would be:

```
username=gar
```

```
groupname=gar
```

and to let the system assign the numeric id's. Log in as, or 'su' to, this user whenever you install new releases, change configuration files or start background processes such as Gspool.

Here is an outline of why this is recommended:

- This user will own all files created by the installation routine, making it easy to identify files belonging to Host Links.
- If you use a disk quota system, the files' disk space will not be deducted from the quota of whoever installed them.
- This user can own all daemon processes, such as the background Gspool and GUFT servers, making them easy to identify.
- Host Links can be installed in such a way that only users belonging to the `gar` group can access the software.

# Preparation

## Copy the software to your system

If the Host Links installation files are on a file server somewhere, copy them to a temporary directory (e.g. /tmp/hlinstal) on your system. Use `chmod` to set the necessary permissions; 'rw' on `bas38612.640`, `gjs38612.640`, `install.640` the `srb` and `licenses`, e.g. `chmod 664 filename`. Set the x-bit on the unzip program: `chmod 775 unz38612`.

## Create user gar

Before installing Host Links or any of its associated software you should create a user for administration of the Host Links software. Create a new user id `gar` and group id `gar` on your UNIX/Linux system.

## Create directory /usr/gar

Log in or 'su' to the `root` user, create the directory `/usr/gar` and make the `gar` user the owner of it with the `chown` command.

## Log out, then in again as gar

Log out, and then log in again as `gar` before continuing with the rest of the installation (or `su` to the `gar` user id).

## Disable old Host Links releases

Stop all Host Links servers. The simplest way to stop the servers is to use `Gman`. From the `Gman` main window select each server in turn, and use `F3` to issue the **DOWN** command.

Stop all host links clients using the command interface. Remember utilities such as `Gdir`, `Gman` etc. Then use `glicense -i remove` to release the license IPC. See section entitled **Tools** under **Server administration** for a description of `Glicense`.

Remove any old Host Links system directories from your search path.

# Installation

## Run the installation script

The installation script does not overwrite configuration files that you have changed at your site. The sample files delivered will only be installed when you do the first time installation, not when you do upgrades. The same installation script is used both for new installations and for upgrades of old ones.

`cd` to the directory that contains the delivery files (`/tmp/hlinstal`).

Start the installation script with:

```
sh install.640
```

It shows you the user id and group id you are running with and reminds you that this user will own all files. Please check that you are running as user id `gar` and have group id `gar`, unless you are very sure that you want something else.

It offers to set permissions so that only members of the `gar` group can use the products. Accept the default, which gives all users access (read and execute permissions for others), unless you intend restricting access to the group id you are using for installation.

It asks for the directory into which you will install. The default suggested is `/usr/gar`. If you already have a Host Links installation and choose a new directory the installation is done as for installation on a new system including the sample configuration files, and you must thereafter copy over your various configuration files from your old installation.

It asks if you are installing a Host Links system that will be shared by several platforms, for example by NFS mounting the Host Links 'System directory'. Accept the default unless you plan to do this.

## Choosing the correct DSA transport

The script informs you that there are two transport interfaces, and gives you the choice:

```
This delivery contains communication 'line modules' for DSA over
RFC-1006 (TCP/IP) transport and DSA over OSI transport. DSA over
OSI transport is necessary only for historical reasons, because
```

## UNIX/Linux

Datanets, MicroFEPs and the GCOS7 ISL do not have TCP/IP support.

Your choices are:

1. DSA over RFC1006 only
  2. DSA over OSI and RFC1006 (requires OSI stack)
- Your choice is [1]?

Choose option 2 only if you are absolutely sure that you need OSI-transport, and have an OSI-transport stack on your system. Please note that if you choose 2 during the installation and do not have an OSI stack installed, Host Links might fail to start. If you have an OSI stack installed on your UNIX machine and choose 2 during the installation, but later remove the OSI software, Host Links might not work anymore.

You can correct this by changing the symbolic links in the `/usr/gar/bin` directory:

```
rm gl_dsa; rm nl_dsa; rm gl_dsa
ln gl_dsa.rfc gl_dsa
ln nl_dsa.rfc nl_dsa
ln gl_dsas.rfc gl_dsas
```

### **The licenses file**

If some of the product license keys are missing from the supplied licenses file, or if this file isn't supplied electronically with the software, the license can be installed later by copying a valid `licenses` file to the `/usr/gar/config` directory. Note that if you are updating a Host links system then it is important that earlier licenses are cleared. See section entitled *Updating a license*.

## **Review the release information**

When all the files have been installed, the ASCII version of the SRB `srbh1.640` will be found in `/usr/gar/install`. The installation procedure writes a log `instlog.640` in the same directory, and also installs sample configuration files there so as not to overwrite files from a prior release. For a first time release, sample configuration files are installed in the correct directories.

## Set the path

Use the system-wide `/etc/profile` shell script to add `/usr/gar/bin` to the path for all users.

## Allow rlogin mode for Host Links

If you will be using the rlogin mode of the G&R TCP/IP line handler (`gl_tcp`) when using G&R products to reach other UNIX/Linux systems you must carry out an extra step as superuser:

```
su
cd /usr/gar/bin
chown root gl_tcp
chmod u+s gl_tcp
```

## Install the network software

The G&R communications products for accessing the Bull primary network use the DSA session protocol. This session protocol is delivered by G&R, but requires a transport interface on the Host Links platform. If your Bull mainframe has RFC1006 support then no more communications software is required. We include RFC1006 in Gline. If your Bull mainframe does not have RFC1006 installed, or if you choose not to use it, you will need an OSI-transport stack. There is no OSI-transport stack for Linux.

## Build network configuration (`dsa.cfg`)

After the installation program has been run, the file:

```
/usr/gar/config/dsa.cfg
```

will contain an example of a DSA configuration. This must be modified to reflect your network and the systems you will be accessing. See the sample file in the section entitled *Sample dsa.cfg* on page 27. Please refer to the *G&R/Gline manual* for more details and examples.

Remember to compile `dsa.cfg` with the 'gcc' program **every time** you have modified your `dsa.cfg` file.

## Test

Test your configuration. You will find the DSA test utilities useful e.g. *Gping*

```
gping -li dsa -dn b7d1 -da iof -du jim -pw mydogsname
Gping - $$DSA: Connected to application
```

For details of the test utilities please refer to the Appendix.

## Configure the Host Links servers

Host Links servers are started by simply executing the command line, see the product manuals for command lines and parameters. You can start them manually for test purposes, but typically you should set up the system such that the command is run each time the system boots. This applies particularly to Ggate and the DSA listener, but can also be used to start Gspool instances that will listen for incoming connections and for the GUFT server. Gspool instances which listen for DSA connections and the GUFT server are however best set up for start on demand, see the section entitled *Starting applications on demand*.

Note that because Ggate forks a new process for each connection, it needs to be run by a user ID that has privileges to fork many processes. Typically this means running `gg_tcp` as `root` and not as the *Host Links* administrator user ID. The DSA listener also forks processes if configured to start programs on demand, but usually the default UNIX/Linux value for the number of forked processes is sufficient. However, if it is accepting incoming RFC1006 connections it must run as `root`, because access to the RFC1006 port is restricted to `root`.

## Command line syntax

Products may be started at the UNIX/Linux prompt, or from shell scripts etc. with commands in the form:

```
product [-xx yyyyyy ]
```

where `-xx yyyyyy` is one or more legal parameters e.g.:

```
gg_tcp -k 60 -cpara '"-da iof -dp ourproject"'
```

starts Ggate using a 60 seconds keep-alive timer on client sessions. Appends the parameters `-da iof` and `-dp ourproject` to all client connections.

## Start at system startup

On AIX systems you can start the Host Links servers directly from `/etc/inittab`, by placing the command lines at the end of the file:

```
gg_tcp:2:once:/usr/gar/bin/gg_tcp
nl_dsa:2:once:/usr/gar/bin/nl_dsa
gspool:2:once:su gar -c "/usr/gar/bin/gspool -dpf8 -id gs9 -dpfq -pc lp
-li tcp"
```

On many other systems you can create a shell script e.g. `S99gar` with the content below, and place it in the `/etc/rc2.d` directory:

```
/usr/gar/bin/gg_tcp
/usr/gar/bin/nl_dsa
su gar -c "/usr/gar/bin/gspool -dpf8 -id gs9 -dpfq -pc lp -li tcp"
```

The format and placement of these installation scripts vary from OS to OS and between versions of the same OS. Please consult your operating system manuals in order to obtain the correct method for creating startup scripts.

## Starting applications on demand

Applications can be started on demand when DSA connections arrive. Currently Gspool and GUFTSRV can be started in this way, as well as user-written applications using GIAPI.

The `nl_dsa` listener handles this, so this must be started. A configuration file controls the mapping from the DSA mailbox name (`-mn`) and, optionally, extension (`-mx`) to the command line for the application to be started. There is one file for each DSA node name (SCID) for which connections are being accepted. It is placed in the

```
/usr/gar/servers/<SCID>.gli
```

directory. The file is either `config.dsa` or `config.diw` for `nl_dsa` and `nl_diws` respectively.

Example file `/usr/gar/servers/grdl.gli/config.dsa`:

```
* Three printer mailboxes
listen -mn printer1 -cmd gspool -pc "lp -dprt1"
listen -mn printer2 -cmd gspool -pc "lp -dprt2"
listen -mn printer3 -cmd gspool -pc "lp -dprt3"
* UFT server
listen -mn filetran -cmd guftsrv
* User written application
listen -mn userapp -lim 1 -ext -cmd userapp arg1 arg2
```

See the *Host Links Gline* manual for details of start on demand.

# Environment

---

## Set Host Links profiles

The profiles are used to set various parameters for customization of the Host Links environment. This will in general not be necessary unless you have special needs. For information on the files and the available parameters see the manual *Installation & Configuration of Host Links Emulators*.

## Environment variables

Some configuration can only be done using UNIX/Linux environment variables.

### **PATH**

It is recommended that you add the location of the Host Links program files to your PATH. The location is `/usr/gar/bin` by default. The PATH update will normally be done for all users in the system-wide `/etc/profile` shell script, but can be set individually.

### **GAR\_SYSDIR**

This is not normally set. If you did not install Host Links in the default directory, `/usr/gar`, it has to be set to the name of the directory where you did install it.

### **GAR\_MODE**

This is not normally set. In some circumstances it may however be useful to specify the mode part of the Host Links user ID. It can be used to select special sections from Host Links profiles and configuration files.



# Server Administration

---

## Gmanager

Gmanager is the Host Links administration tool. It can be used to control, configure and monitor all the G&R Host Links server programs.

The dialog and interaction between the server programs and Gmanager is based on information located in a database file `_active.srv` that is located in the Host Links `servers` directory. The first time a Host Links server program starts up it registers itself in this ‘active’ file. Thereafter the server program updates this database with status information whenever the server is active.

The Gmanager program is available in 2 different versions – a Windows GUI based version `gmanw.exe` and a character based subset `gman` (UNIX/Linux binary) or `gman.exe` (PC console application).

The basic functionality of the two versions is the same, but the Windows version interfaces directly to other Windows-only Host Links administrative tools (*Gconfig*, *Gservice*), and can also start the browser directly to view HTML reports produced by *Gproxy*, if enabled, or to view the HTML pages associated with a *Gweb* or *Glink for Java* installation.

The *Gproxy* reports, *Gweb* and *Glink for Java* web pages are of course available to administrators of UNIX/Linux Host Links systems, and can be viewed by starting a browser manually, and connecting to the appropriate URLs:

```
http://mysite.mydomain.com/Gproxy
http://mysite.mydomain.com/Gweb
http://mysite.mydomain.com/GlinkJ
```

A summary of the available functions follows. The Windows-only functions are marked.

## UNIX/Linux

Gmanager can be used to perform the most common Host Links administrative tasks i.e.:

- View the last reported status information from the servers
- Stop or restart all servers, start a new server, stop, restart or delete a server
- Send a command to a server
- Load the DSA configuration into an editor, compile the DSA configuration
- Start the server configuration program or the configuration wizard (Windows)
- Load the *Gservice* configuration into an editor (Windows)
- Edit the product specific configuration files
- View a server log file, a server trace file or the server configuration file
- View program version numbers, program link information (Windows)
- View license info and license usage (Windows)
- View Host Links environment information, the 'VMAP' (Windows)
- Start Gdir directory administrator, Ggate monitor, Gspool monitor
- Gather all traces and logs for trouble-shooting by support
- Gping a DSA node to check the connection, use Gerror to explain error code
- Set a transport route state (down, enbl, lock, used)
- Check if a printer is on-line, request a list of bins
- Connect directly to the *Gproxy*, *Gweb*, *GlinkJ* HTML pages(Windows)

The commands that are accepted by all servers are:

- DOWN - terminates the server
- STATUS - reports server-specific status information to the log file
- PARAM - allows the operator to give a command line parameter to the server. Note that some parameters do not work when given interactively i.e. they can only be handled at server startup time
- DEBUG ON/OFF - toggles on and off tracing interactively

Additionally, the server in question might support other interactive commands. For a description of the supported commands, check the server-specific documentation.

# Gdir

This is a directory navigation and file edit/display/execute tool. The editor and display programs used are configurable so you can replace them with your favorites. The keyboard is configurable so that you can add shortcut keys that make several of your favorites available for use on the selected file. Gdir is supplied as a character based utility `gdir` (UNIX/Linux binary) or `gdir.exe` (PC console application).

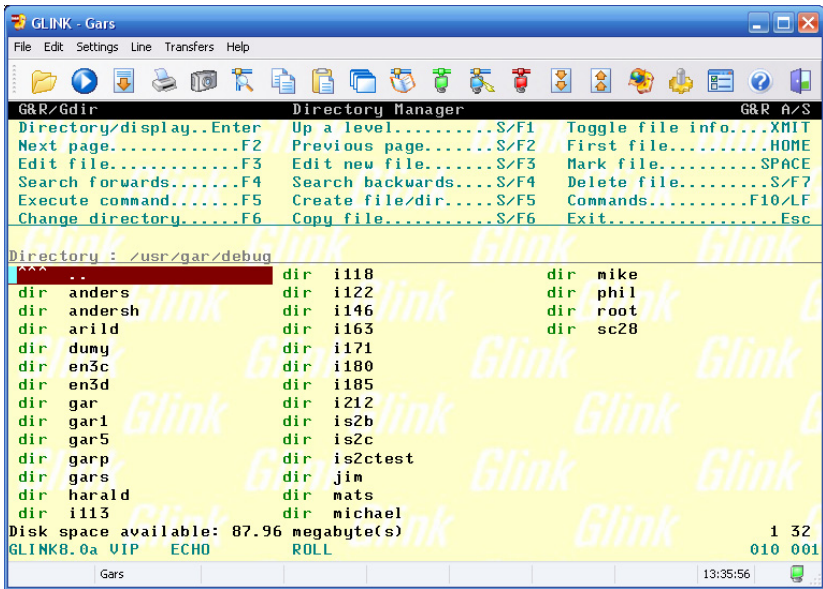

You might find this very useful when navigating in the Unix/Linux file system to look for Host Links configuration or trace files. In the Windows environment it offers somewhat different functionality than MS Explorer.

# Tools

## Glicense

Glicense is supplied as a character based utility `glicense` (UNIX/Linux binary) or `glicense.exe` (PC console application). The utility can be used to read, modify and update a license, but these functions are not generally available to users. When the first Host Links product is started the license is read into a shared memory segment (IPC, Inter Process Communications) and thereafter read and updated by all Host Links products under the control of a shared semaphore. Glicense display functions (`-i`) are generally available and can give you information regarding the shared memory area and license usage. This documents the UNIX/Linux version, the Windows version is a subset.

`glicense`

read, modify update a license not generally available

`glicense -i`

Usage: `glicense -i option`                    options listed below

`info`

IPC size and usage e.g.

License IPC area size=1996, licenses=7, key=0x8a52ad08, users=2

`show [ACTIVE|product]`

License usage e.g.

`gljsrv/100/0 inuse=1 #1`

`reserve PRODUCT`

`clean`

remove 'dead' licenses

`remove`

delete the IPC

When updating a UNIX/Linux license you first terminate all Host Links products, and the use `glicense -i remove` to release the IPC and semaphore.

Some useful UNIX/Linux commands for checking the Host Links license area and cleaning up after a system crash are:

`ipc -ms`

display shared memory and semaphores

`ipcrm -m <id>`

release shared memory

`ipcrm -s <id>`

release shared semaphore

## Gver

This is a utility program that lists the version number of the G&R Host Links release programs that you are using. Gver is supplied as a character based utility `gver` (UNIX/Linux binary) or `gver.exe` (PC console application). It can be used to list only the release number, or to list details of all G&R software installed:

```
jim@gars ~ $ gver -r  
6.4.0d/spaso
```

```
jim@gars ~ $ gver  
3270web 368892 gweb/cpicweb 6.4.0d/spaso Aug 9 2007 10:41:29  
5250web 407420 gweb/cpicweb 6.4.0d/spaso Aug 9 2007 10:41:29  
7800web 404580 gweb/cpicweb 6.4.0d/spaso Aug 9 2007 10:41:29  
dkuweb 403844 gweb/cpicweb 6.4.0d/spaso Aug 9 2007 10:41:29
```

## Gdump

This utility program lists the Host Links environment. It is supplied as a character based utility `gdump` (UNIX/Linux binary) or `gdump.exe` (PC console application).

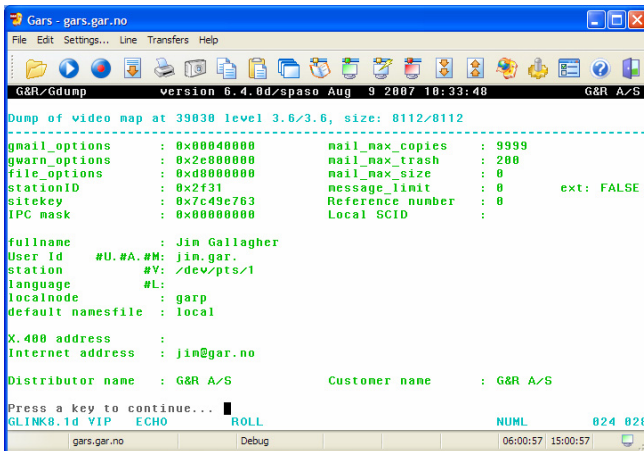

# ***Host print in DSA networks***

---

## ***Print to screen session***

If the mainframe application mixes print with normal screen output using print addressing for the print blocks, and screen addressing for screen blocks the DSA line module or Ggate simply pass print output to the client: a Host Links emulator, Glink, or if using TNVIP or Telnet, to a third party emulator.

## ***Print on separate session***

If mainframe print output is being sent to an independent mailbox then the DSA configuration file can be set up to merge this print session with the terminal session. The resulting merged session looks to the client Host Links emulator, Glink or third party emulator as if the application had used print addressing. Please refer to the *Gline* manual for details of the `-pco` option. Alternatively a copy of Gspool can accept the print as described below.

## ***Gspool***

If mainframe print output is being sent to an independent mailbox (a free-standing ROP printer mailbox) Gspool can be used to accept the print. Gspool functions quite independently outside of the user process and may be configured to connect to the mainframe, or to wait for the mainframe to connect to Gspool. Printers configured in DPF8-S&F must log on to GCOS8. Printers configured in RSM8 on GCOS8, in Twriter on GCOS7 and printers configured in the SNM on GCOS6 all wait for the mainframe to connect to them. There is no Remote Batch facility available in Host Links, so GCOS8 SYSOUT has to be delivered to Gspool via a GCOS8 SYSOUT spooling program such as DPF8-DS, RDF8, RSM8 or Dispatch8.



# Sample dsa.cfg

---

The following file is the sample delivered with Host Links for UNIX/Linux, and is found in

```
/usr/gar/config/dsa.cfg
```

The hash characters denote comments, and would be removed after the file has been edited to reflect your site and remote nodes.

```
# The Gline configuration compiler, glcc, must be run to activate any
# changes made here.
# The following directives are used to configure the network:
# sc      - Session control
# rsc     - Remote session control
# ts      - Transport station
# tp      - Transport provider

# For more information and sample dsa.cfg files read the Host Links
# Gline documentation. Only RFC1006 transport is supported on all
# platforms. If you need OSI-transport contact G&R.

# RFC1006 Example
# -----
# Your local DSA RFC1006 node name is 'is2c'.
# You want to connect with remote DSA RFC1006 node name 'ph21'
# that has IP address 1.2.3.4 and 'ka01' that has 5.6.7.8

# is2c needs a dsa200 address when connecting to GCOS7
# sc is2c -addr 05:44

# Remote node GCOS8 ph21
# rsc ph21 -ts ph21_rfc
# ts ph21_rfc -class 0 -ns 1.2.3.4 -tp rfc

# Remote node GCOS7 ka01 needs a dsa 200 address
# rsc ka01 -addr 176:072 -ts ka01_rfc
# ts ka01_rfc -class 0 -ns 5.6.7.8 -tp rfc

# Use Gallagher & Robertson RFC1006 stack
# tp rfc -who gar
```

## UNIX/Linux

```
# Coname configuration example
# -----
# See the Gline manual for information about configuring
# conames and setting up filters to control access to them.
#
# In Glink you select a coname by specifying it in the Ggate
# configuration dialog box.
# In Host Links a coname is selected with the '-co' parameter.
#
# You want to use a coname 'tp8ws2' to access TP8.
# It references a pool of mailbox extensions so it
# can be shared by a group of users.

# coname tp8ws2 -desc "TP8 workstation 2" -pool lidpool
#   -dn ph21 -da tpws2mbx -hm dps8

# pool lidpool
#   -dx mg01
#   -dx mg02
#   -dx mg03
#   -dx mg04

# A convenient shorthand for configuring large pools:

# pool lidpool
#   -dx mg[01-04]

# conames are also used for configuration of merged print,
# where data from a separate print session is merged into the
# terminal session, marked as print data.

# Merged print from TWriter on GCOS7. Use -pco to get a printer
# The printer coname must wait for a connect from Twriter to
# the printer mailbox mypctw.
#
# coname mytds -desc "TDS on GCOS7"
#   -dn ka01 -da tdsmbx -hm dps7 -pco a2_print

# coname a2_print -desc "Twriter print to MYPCTW"
#   -ln -mn mypctw -tm a2

# end of dsa.cfg
```

# Appendix: Host Links Manuals

---

Below you find a complete list of all available Host Links manuals:

<b>Installation</b>	
Host Links Servers	Installation and Configuration on UNIX/Linux
Host Links Emulators	Installation and Configuration on UNIX/Linux
Host Links	Installation and Configuration on Windows
<b>Line handling</b>	
Gline	Line Handler and DSA/OSI Configuration
Ggate	Transparent Gateway
Gproxy	Network Manager & SNMP Proxy Agent
G&R SSL	Using SSL for security in G&R products
GIAPI	Application Programming Interfaces
<b>Emulations</b>	
Gspool	Network Printer Emulation
GUFT	Unified File Transfer
G3270	Emulating IBM 3270 Terminals
G5250	Emulating IBM 5250 Terminals
Pthru	Gateway to the Bull Primary Network
Qsim	Emulating Questar DKU7107-7211 & VIP7700-7760
V78sim	Emulating VIP7801 & VIP7814
Gweb	Web Browser Front-end for DKU, VIP7700-7760, VIP7800, IBM3270 and IBM5250 Emulations



# Appendix: The text library

---

All the messages used by Host Links are kept in the text library `progtext[.ccc]` in directory `gar`, sub-directory `misc`, so the default texts for a site can be changed using the `gcptexts` utility:

## *gcptexts - Maintain program texts*

```
gcptexts [-v] [-x module] [-o] library [[file] [file]..]
```

```
where          <library> is progtext with all module texts
<module>      is a text module number to export, or 0 for all
<file>        are the files containing program texts to import
```

```
Flags -x      export, default is to import
      -v      verbose mode
      -o      overwrite ok when exporting
```

The host Links modules using the message library are:

Module	number for export
divutl	001
gdir	011
gedit	016
gline	006
glist	013
gmail	012
gmailer	015
gmenu	014
guft	028
gweb	030
mailutl	002

The texts are exported to one file for each module into the directory where `gcptexts` is executed. The file names are fixed and the same as the module name e.g. file 'gline':

```
#006 Attention: Do NOT modify this line!
001 You are not logged on to the gateway.
002 You are already logged on to the gateway.
003 You are not connected.
004 Already connected.
005 -LL parameter out of range.
```

## ***Procedure for modifying the library***

For simplicity copy the library `c:\gar\misc\progtext` to a work directory. Export the message texts you want to modify, e.g. the texts used by Gline (module 6):

```
gcptexts -v -x 6 progtext
```

This creates the file `gline` in your work directory.

Modify the file (not the first line identifier) and then import the messages into your working copy of `progtext`.

```
gcptexts -v progtext gline
```

You can import from multiple files using any file names, it is the first line identifier that tells `gcptexts` the name of the module:

```
gcptexts -v progtext mygline mygweb
```

Take a backup copy of `c:\gar\misc\progtext` and replace it with your modified version. You will need to restart the program concerned for the new texts to be taken into use.

Note that you can have several different `progtext` libraries, and select the one to be used by adding a `LANGUAGE` directive to the profile used by an individual user or group of users. The libraries are identified by a suffix of up to three characters e.g. `progtext.fr`, and this would be selected by adding the directive `LANGUAGE FR` in the profile. See the chapter entitled ***Profiles configuration*** for details. The default is `progtext` with no suffix, and if all users speak the same language you can simply update `progtext` with your translated version of the texts.

# Appendix: Error Codes

---

## OSI/DSA error codes

Below is a list of OSI/DSA error codes and the corresponding description. These are the same descriptions that the `G&R/Gerror` utility will display when given the DSA code as a parameter.

code	Description
<b>00xx</b>	<b>General Errors</b>
0001	Open Failure in LC - Reject for unknown reason
0002	Open Failure in LC - Acceptor customer node inoperable
0003	Open Failure in LC - Acceptor customer node saturated.
0004	Open Failure in LC - Acceptor mailbox unknown.
0005	Open Failure in LC - Acceptor mailbox inoperable.
0006	Open Failure in LC - Acceptor mailbox saturated.
0007	Open Failure in LC - Acceptor application program saturated
0008	Connection refused. Transport protocol error or negotiation failed.
0009	Open Failure in LC - Dialog protocol error or negotiation failed
000A	Open Failure in LC - Presentation protocol error or negotiation failed
000B	Open Failure in LC / Connection refused lack of system resources
000C	Open Failure in LC / Connection refused from GCOS7 duplicate user
000D	Open Failure in LC, Duplicate implicit LID / Q class not started
000E	Open Failure in LC, Duplicate GRTS Id / lack of memory resources
000F	Open Failure in LC, No Logical line declared for DACQ / 7 connection refused
0010	Open Failure in LC, GCOS 8 GW Missing translation / Incorrect device length in ILCRL.
0011	Open Failure in LC, DAC connection not initialized / Too many jobs executing
0012	Open Failure in LC, No binary transfer / impossible to start the IOF job
0013	Open Failure in LC, connection is not negotiated in FD mode / impossible to start the IOF job

0014	Disconnection - Timeout resulting from absence of traffic.
0016	Option missing for an RBF mailbox.
0017	Connection refused - Incorrect access right for MB.
0018	Connection refused - Incorrect access rights for the application.
0019	Connection refused - Unknown pre-negotiated message path
001A	Connection refused - Security validation failed.
001B	Connection refused - Unknown acceptor mailbox extension.
001C	Connection refused - Inoperable acceptor mailbox extension.
001D	Connection refused - Invalid Message group number.
001F	Disconnection - no more memory space.
0020	Connection refused - Unknown node.
0021	Connection refused - inaccessible node or Host down.
0022	Connection refused - saturated site.
0023	Connection refused - inoperable mailbox.
0024	(X.25) Packet too long. Problem with packet size. / Connection block already used.
0030	Syntax Error - option not known (received on close VC).
0031	(X.25) No response to call request packet - timer expired.
0033	(X.25) Timer expired for reset or clear indication.
0039	Disconnection - transport protocol error (MUX).
003C	Presentation Control Protocol Error
003E	The application has not the turn
003F	Message group closed
0040	(X.25) Facility code not allowed. / Connection refused - unknown node
0041	Connection refused - path not available.
0042	Connection refused - Duplicate USER ID / Facility parameter not allowed
0044	(X.25) Invalid calling address.
0045	(X.25) Invalid facility length.
0047	(X.25) No logical channel available.
004F	DNSC: (X.25) Invalid call packet length.
0050	Normal disconnection (GCOS3/8)
0051	Error or Event on LC initiated by GW
0052	Error or Event on LC initiated by GW.
0053	Error or Event on LC initiated by GW. TCall
0054	Error or Event on LC initiated by GW. DIA in LOCK State
0055	Error or Event on LC initiated by GW. DIA error
0056	Error or Event on LC initiated by GW. GW has no known explanation.
0057	Error or Event on LC initiated by GW. Reject mailbox permanent

0058	Error or Event on LC initiated by GW. No more input lines in DACQ
0059	Time-out on GCOS 3/8 gateway.
005A	Error or Event on LC initiated by GW. Disconnect from terminal without reason
005B	Error or Event on LC initiated by GW. Wrong letter or wrong record
005C	Error or Event on LC initiated by GW. Forbidden letter received
005D	Error or Event on LC initiated by GW. Forbidden letter received
005E	Error or Event on LC initiated by GW. No buffer for secondary letter
005F	Error or Event on LC initiated by GW. No buffer for fragmented letter
0060	Error or Event on LC initiated by GW. Disconnect on end of phase record
0061	Error or event on LC initiated by GW. No buffer for control letter.
0062	Error or event on LC initiated by GW. Mailbox in closing phase
0064	Error or event on LC initiated by GW. Flow control error.
0065	Error or event on LC initiated by GW. CH locked by operator.
0066	Error or event on LC initiated by GW. Disconnect with a normal TMG F2 exchange.
0067	Error or event on LC initiated by GW. Teletel rerouting error from DACQ
0068	Error or event on LC initiated by GW. Teletel routing error from DACQ
0069	Error or event on LC initiated by GW. Teletel rerouting error from TM
006A	Error or event on LC initiated by GW. Teletel rerouting error from TM
006B	Syntax error - text too long.
006C	Syntax error - illegal object in a GA command.
006D	Syntax error - unknown node Id.
0078	Syntax error - illegal command for this object.
0079	Syntax error - illegal date.
007F	(X.25) No route available for X.25 switching.
0081	No more network routes available for switching.
0082	(X.25) Hop count reached for X.25 switching.
0083	(X.25) Flow control negotiation error.
0085	(X.25) Frame level disconnection.
0086	(X.25) Frame level connection.
0087	(X.25) Frame level reset.
0090	Frame level not set.
0092	(X.25) X.25 Echo service in use.
0093	(X.25) Incorrect password for PAD connection.

0094	(X.25) No more PAD connections allowed.
0096	(X.25) TS SX25 or NU X25 objects locked.
009C	(X.25) Invalid packet header. X.25 protocol error.
009D	(X.25) Incompatible header. X.25 protocol error.
009E	(X.25) Logical Channel Number too high.
009F	(X.25) Incorrect packet type.
00B2	Use of invalid password through PAD
00B6	Unknown mailbox selection for PAD connection using the PAD password.
00C0	(X.25) Normal disconnection.
00D7	(X.25) TS image (of type DSA or DIWS) in LOCK state.
00DE	(X.25) NS RMT or NR SW in LOCK state.
00E1	Connection refused. Mailbox is not in ENBL state.
00E6	QOS not available permanently.
<b>01xx</b>	<b>Session Control</b>
0100	Logical connection accepted or normal termination
0101	Rejection for unknown reason or abnormal termination
0102	Acceptor node inoperable.
0103	Acceptor node saturated. When a node has no available resources
0104	Acceptor mailbox unknown.
0105	Acceptor mailbox inoperable.
0106	DNS: Acceptor mailbox saturated.
0107	DNS: Acceptor application program saturated.
0108	Transport protocol error or negotiation failed (DSA 200 only).
0109	Dialog protocol error or negotiation failed. (Wrong logical record).
010A	Time-out on session initiation / unknown LID
010B	Acceptor mailbox extension unknown.
010C	Acceptor mailbox extension inoperable.
010D	Invalid Session Number.
010E	Unknown node.
010F	System error. System generation error or insufficient memory space
0110	Application abnormal termination. Subsequent to an abnormal occurrence in the dialogue
0111	Normal terminate rejected.
0112	Protocol not supported.
0113	Session control service purged by user.
0115	Disconnection Time-out on message group initiation.
0117	Incorrect Access Right for MB
0118	Incorrect Access Right for the Application
0119	Pre-negotiated Message Path Descriptor unknown
011A	Security validation failed
011E	Incorrect object status

011F	Not enough memory space available.
0120	Node unknown.
0121	The channel object (CH) is in LOCK state
0122	Saturation - no plug available
0123	Object status = LOCK
0124	Connection block (TSCNX) already used
0125	Disconnection already running
0126	The connection block (TSCNX) is disconnected (or not connected)
0127	Change Credit value < 0
0128	Ineffective Change Credit ( delta = 0 )
0129	No more deferred letters
012B	"Reinitialization" Request
012C	"Reinitialization" in progress
012D	"Reinitialization" in progress, letters are dropped
012E	Close virtual circuit. Either no mapping exists between PA/NR or CL and VC/NS
012F	Null connection object index.
0130	Undefined function at Sysgen time.
0131	Letter too large with respect to the negotiated size.
0132	The received letter is longer than the size which was
0133	Disconnection of the session control user
0134	Interface error on EOR (End-Of-Record) processing.
013C	Presentation control protocol error.
013E	You do not have the turn.
013F	Message group closed.
0140	Session is closed.
0151	Request refused, no system buffers available.
0152	Incorrect addressing record.
0153	No presentation record in the ILCAL or ILCRL
0154	Negotiation failed on session mode
0156	Negotiation failed on resynchronization.
0157	Negotiation failed on END to END ACK
0158	No presentation record in the connection letter
0159	Negotiation failed on session mode
015A	Negotiation failed on letter size (in the Logical Connection record).
015B	Negotiation failed on resynchronization (in the Logical Connection record).
015C	Negotiation failed on end-to-end ACK (Logical Connection record).
015D	No support of the "letter" interface because Multirecord is not negotiated.
0160	Incorrect TSPACNX table.
0161	Protocol error on letter reception.

0162	Negotiation failure.
0163	Record header length error.
0164	Protocol error.
0165	Protocol error reception of control letter.
0166	Type or length error on interrupt letter.
0167	Protocol error on reception of data letter.
0168	Dialog protocol error.
0169	Unknown event.
016A	Protocol error on data transfer.
016B	Invalid status for a disconnection request.
016C	Invalid status for a recover
016D	Invalid status for a suspend/resume request.
016E	Negotiation failure.
016F	Unknown command.
0170	Error in presentation protocol
0171	Letter header length error in
0172	ILCAL is not DSA 200 protocol.
0173	Error in session record.
0174	Normal disconnection, without complementary reason code.
0175	Letter is not in ASCII or EBCD.
0176	Connection protocol letter header
0177	Letter header protocol error.
0178	Record header protocol error.
0179	Record header length error.
017A	Mbx record header length error.
017B	Error on buffer transfer.
017C	DSA 200 record header protocol
017D	DSA 300 record header protocol
017E	Unsupported connection options.
017F	Character error in ASCII string.
0180	No segmented record size.
0181	Invalid mailbox object index.
0182	Mapping error for a remote connection.
0190	No more buffers.
0191	Byte count is greater than GP.
0192	Byte count is greater than GP.
0193	Byte count is greater than GP.
0194	Byte count is greater than GP.
0195	Byte count is greater than GP.
0196	Byte count is greater than GP.
0197	Byte count is greater than GP.
0198	No more buffers.

0199	Byte count is greater than GP.
019A	Byte count is greater than GP.
019B	Byte count is greater than GP.
019C	Byte count is greater than GP.
019D	Byte count is greater than GP.
019E	Byte count is greater than GP.
019F	Byte count is greater than GP.
01A0	Invalid transfer state.
01A1	Suspend protocol running.
01A2	Suspend protocol running.
01A3	Recover protocol running.
01A4	Forbidden function in write request. (\$WRITE)
01A5	Conflicting parameters for segmented record. (SWBREC)
01A6	Protocol conflict - suspend/recover.
01A7	Protocol not supported - letter/end-to-end ACK. (SWBLET)
01A8	Multi-record letter in progress.
01A9	Interrupt request forbidden.
01AA	Send control record request forbidden. (SCTROL)
01AB	Forbidden for TWA session - turn is here. (SREAD)
01AC	Termination forbidden - suspend or recover in progress. (STERM)
01C0	No space available for downstream connection request. (SMECNX)
01C1	No space available for upstream connection request. (SMUCNX)
01C2	No space available for upstream SCF connection. (SMRCNX)
01C3	No space available for session context. (\$SCTX)
01E0	Enclosure or data length error for a write request. (\$WRITE)
01E1	Enclosure or data length error for a write segment record request. (SWBREC)
01E2	Enclosure error for 'give turn' request. (SGVTRN)
01E3	Interrupt request is not demand turn, attention/data attention, or purge record.
01E4	Input status for a send control letter is not permitted.
01E8	Write request without turn.
01E9	Write segmented record request without turn.
01EA	Write segmented letter request without turn.
01EB	Send control letter request without turn.
01EC	Disconnection request without turn.
<b>02xx</b>	<b>Presentation Control</b>
0201	Protocol level not supported
0202	Application designation protocol error.
0203	Character encoding error. TM cannot support the proposed encoding.
0204	Character set error. TM cannot support the proposed character set.

0205	Character subset error. TM cannot support the proposed character subset.
0206	Incorrect record encoding.
0207	Incorrect parameter encoding.
0230	Data presentation control error. The presentation control proposed for this session cannot be used
0231	Device type is incompatible with the configuration.
0232	TM control protocol is incorrect.
0233	Device-sharing attributes are invalid.
0234	Initiator or acceptor configuration is not correct.
0235	Logical device index error.
0236	Number of logical devices is incompatible with the configuration.
0237	TM protocol record not supported.
<b>03xx</b>	<b>Terminal Management</b>
0300	Sysgen error WARNING. There is no mapped object; some objects will be spare.
0301	Operator requested session abort or logged.
0302	Idle time run out after secondary network failure.
0303	Idle time run out for no traffic.
0304	Form not found.
0305	Operator requested suspension.
0306	Destructive attention send on the session.
0307	Unknown TX addressed in this session. TM is unable to a the session.
030A	Protocol error. A record was received which did not comply with current standards
0310	Insufficient resources. The receiver cannot act on the request because of a temporary
031E	Incorrect value for Retry or Wait parameters on UP LL command.
0320	Function not supported.
0321	Parameter error. This can result
0322	Resource not available. The
0323	Intervention required (on principal device).
0324	Request not executable.
0325	EOI required.
0326	Presentation space altered, request executed.
0327	Presentation space altered, request not executed.
0328	Presentation space integrity lost.
0329	Device busy. The device is busy and cannot execute the request.
032A	Device disconnected.
032B	Resource not configured.
032C	Symbol set not loaded.

032D	Read partition state error.
032E	Page overflow.
0330	Subsidiary device temporarily not available.
0331	Intervention required at subsidiary device.
0332	Request not executable because of subsidiary device.
0340	TM cannot accept a new connection.
0341	Object status incorrect.
0342	The TM configuration is not correct.
0343	Unknown TX addressed on this session.
0344	Data presentation protocol error.
0345	Device type is incompatible with the configuration, or is not supported.
0346	TM control protocol incorrect.
0347	Device shareability attributes are invalid.
0348	Initiator or acceptor configuration is not correct.
0349	Logical device index error.
034A	Number of logical devices incompatible with the configuration.
0350	Disconnection of TM after reinitialization of the network.
0360	File not found. (Welcome and Broadcast Messages)
0361	Site not found. (Welcome and Broadcast Messages)
0362	NASF error. (Welcome and Broadcast Messages)
0370	No-session timeout. Device disconnected.
0371	No-input timeout. Device disconnected.
0372	No-output timeout. Device disconnected.
0373	Timeout due to no backup session being initiated.
0374	Timeout due to no backup session being established.
0375	Connection refused because of late activation of back up session.
0376	Disconnection of current session to switch to backup session.
0380	AUTOCN parameter not declared.
0381	Mixed ETB in data sent by VIP screen and cassette
0382	Data header sent by the terminal incorrect.
0383	Desynchronization in the exchange of data.
0384	KDS block count error.
038C	Remote terminal is not connected
0390	Unknown mailbox.
0391	No call packet to return.
0392	No "Possibility" command to return Protocol error
03C0	Slave device disconnection.
<b>17xx</b>	<b>Network Layer</b>
1701	PAD connection refused.
1702	Flow control error.

1706	Logical channel number not zero in restart packet.
1707	Illegal packet length or use of D-bit forbidden.
1708	Illegal header.
1709	Illegal Logical Channel Number.
1710	Invalid packet type for the automaton state. Protocol error
1711	Incorrect packet type.
1712	Inconsistent network parameters in the generation file.
1713	No more space.
1714	DSAC network layer object not usable.
1717	USED/ENBL transition. Transport station is locked.
1718	USED/ENBL transition. This is a back-up NR.
1719	USED/ENBL transition. Dynamic close due to load.
171A	USED/ENBL transition. Transfer time-out has elapsed.
171B	USED/ENBL transition. This is a back-up NR.
171C	USED/ENBL transition. Transport station is idle.
171E	USED/ENBL transition. NR object is locked.
171F	ENBL/LOCK transition. NR HDLC has no more memory space.
1721	Remote station is inaccessible via the configured network. Check
1723	Incorrect PAD password.
1724	Virtual circuit already in use. LCN (Logical Channel Number) too high.
1725	Invalid virtual circuit.
1726	Packet too short. Protocol error for the equipment directly connected to the Bull Datatet.
1727	Incompatibility between the generation parameters of two communicating systems on window or packet size.
1729	Packet size in communicating systems not the same.
1731	Timer runs out while waiting for call confirmation.
1732	Timer runs out while waiting for clear confirmation.
1733	Timer has run out while waiting a reset confirm.
1740	Call setup or call clearing problem.
1741	Open failure on virtual circuit. No flow control on this NS.
1742	Incorrect facility. Protocol error for the equipment directly connected to the Bull Datatet.
1744	Unknown subscriber.
1745	End of time-out on reset confirm. Invalid facility length. Protocol error for the equipment directly
1747	No logical channel available.
1749	End of time-out on call confirm.
174F	Incorrect packet length. Protocol error for the equipment directly connected to the Bull Datatet.
1755	Flow control, window, packet size or reset error.

1760	Frame disconnection.
1770	Frame connection.
1771	Frame reset.
1781	No more network routes available for X.25 switching.
1782	Maximum of 15 switches have been used,
1783	Flow control negotiation error.
1785	Frame level disconnection.
1786	Frame level connection.
1787	Frame level reset.
1790	Frame level not established.
1791	No more logical paths available for the PAD.
1792	Echo service busy.
1793	Incorrect PAD password.
1794	All the PAD virtual circuits are used
1795	X.25 initialization not possible.
179B	LCN not null in restart packet
179D	Incompatible header (receive error: all VC of concerned NS
179E	LCN greater than NBVC in NS directive
179F	Incorrect packet type
17A0	Invalid facility.
17B0	Normal disconnection.
17B1	X.25 Echo in use.
17B2	No more logical channels available.
17B3	No more PAD connections allowed.
17B4	TS SX25 or NU X25 object locked.
17B5	Buffer capacity overflow.
17B6	Normal disconnection.
17B8	Unknown calling SNPA (Sub-Network Point of Attachment).
17B9	Internet problem.
17CB	Call collision on VC
17CC	Incompatible generations (NR object without mapping).
17CE	Invalid status NR locked.
17CF	Lack of space.
17D0	Unknown subscriber.
17D4	TSCNX already used for another connection. SCF internal error.
17D7	Transport station locked.
17DD	Proper NS locked.
17DE	Invalid status NR locked.
17DF	Lack of space.
17E0	Forbidden parameter or invalid value.
17E1	Invalid transition.
17E2	Upward-mapped object (TS) not locked.

17E3	No object mapped above.
17E4	NR not locked (MP NR -ADD/-SUB) or virtual circuit already open.
17E5	NR is last in list and the TS is not locked.
17E6	No object mapped above (UP NR -PRIO). NR not mapped on TS.
17E7	Upward mapped object not locked
17E9	Mix of datagram and connection network
17EB	Class inconsistent with NR.
17EE	Incompatible generations. NR object without mapping.
17FF	Wrong parameter in administrative CALL
<b>18xx</b>	<b>Transport Layer</b>
1800	Normal disconnection initiated by the correspondent
1801	Local saturation at connection request time.
1802	Failed negotiation at connection time.
1803	Duplicate connection. Two or more requests have been issued for the same connection.
1804	Redundant request.
1805	Retransmission Time-out at transport level.
1806	Survey time-out at transport level.
1807	Transport protocol error.
1808	Session Control specified is not available (inaccessible).
1809	Requested Session Control Id unknown by remote transport.
180A	Termination because of disconnection by administration.
180B	Session Control/Transport interface error.
180C	Connection request on non-sharable VC in case of ISO Transport. ISO: header or parameter length is invalid.
1817	Station in shut-down state.
181F	No memory space at connection time.
1821	Session Control inaccessible by configured session routes. ISO: Session entity not attached to TSAP.
1824	Collision between Close NC and Open TC.
182E	Remote station not configured.
182F	Resource saturation.
1831	ISO: No route for the called NSAP.
1832	ISO: Received NSAP addresses are wrong.
1833	Segmentation violation.
1834	ISO:QOS priority not available temporarily, due to a local condition (for example, lack of resources).
1835	ISO:QOS priority permanently unavailable locally (for example, due to an error in the system generation).
183A	ISO: Remote reason not specified.
183C	ISO: Remote transport entity congestion at connect request time.
1840	Server in terminating state. TC has been re-assigned on another NC.

18A1	An additional NC has been assigned to a TC.
18B0	NC has been re-assigned on another VC.
18EF	Disconnection at Transport level caused by reception of RESTART DSA during the transfer phase.

## Windows Sockets error Codes

Below is a list of Windows Sockets return codes and the corresponding description.

Hex code	Windows Sockets Access Error name	Description
2714	WSAEINTR	The (blocking) call was cancelled via WSACancelBlockingCall()
2719	WSAEBADF	The socket descriptor is not valid.
271E	WSAEFAULT	An invalid argument was supplied to the Windows Sockets API.
2726	WSAEINVAL	An invalid call was made to the Windows Sockets API.
2728	WSAEMFILE	No more file descriptors are available.
2733	WSAEWOULDBLOCK	The socket is marked as non-blocking and no connections are present to be accepted.
2734	WSAEINPROGRESS	A blocking Windows Sockets call is in progress.
2735	WSAEALREADY	The asynchronous routine being cancelled has already completed.
2736	WSAENOTSOCK	The descriptor is not a socket.
2737	WSAEDESTADDRREQ	A destination address is required.
2738	WSAEMSGSIZE	The datagram was too large to fit into the specified buffer and was truncated.
2739	WSAEPROTOTYPE	The specified protocol is the wrong type for this socket.
273A	WSAENOPROTOOPT	The option is unknown or unsupported.
273B	WSAEPROTONOSUPPORT	The specified protocol is not supported.

273C	WSAESOCKTNOSUPPORT	The specified socket type is not supported in this address family.
273D	WSAEOPNOTSUPP	The referenced socket is not a type that supports connection-oriented service.
273E	WSAEPFNOSUPPORT	
273F	WSAEAFNOSUPPORT	The specified address family is not supported by this protocol.
2740	WSAEADDRINUSE	The specified address is already in use.
2741	WSAEADDRNOTAVAIL	The specified address is not available from the local machine.
2742	WSAENETDOWN	The Windows Sockets implementation has detected that the network subsystem has failed.
2743	WSAENETUNREACH	The network address can't be reached from this host. There is probably a problem in the way you have set up TCP/IP routing for your PC (most likely you have not defined a default router).
2744	WSAENETRESET	The connection must be reset because the Windows Sockets implementation dropped it.
2745	WSAECONNABORTED	The connection has been closed.
2746	WSAECONNRESET	
2747	WSAENOBUFS	Not enough buffers available, or too many connections.
2748	WSAEISCONN	The socket is already connected.
2749	WSAENOTCONN	The socket is not connected.
274A	WSAESHUTDOWN	The socket has been shutdown.
274B	WSAETOOMANYREFS	
274C	WSAETIMEDOUT	Attempt to connect timed out without establishing a connection.
274D	WSAECONNREFUSED	The attempt to connect was forcefully rejected. The service on the other side is not available.
274E	WSAELOOP	Too many symbolic links were encountered in translating the path name.
274F	WSAENAMETOOLONG	
2750	WSAEHOSTDOWN	The host machine is out of service.
2751	WSAEHOSTUNREACH	The host machine is unreachable.

2752	WSAENOTEMPTY	
2753	WSAEPROCLIM	
2754	WSAEUSERS	
2755	WSAEDQUOT	
2756	WSAESTALE	
2757	WSAEREMOTE	
276B	WSASYSNOTREADY	Indicates that the underlying network subsystem is not ready for network communication.
276C	WSAVERNOTSUPPORTED	The version of Windows Sockets API support requested is not provided by this particular Windows Sockets implementation.
276D	WSANOTINITIALISED	A successful WSStartup() must occur before using this API.
2AF9	WSAHOST_NOT_FOUND	Authoritative answer host not found.
2AFA	WSATRY_AGAIN	Non-authoritative answer host not found, or SERVERFAIL.
2AFB	WSANO_RECOVERY	Non-recoverable errors, FORMERR, REFUSED, NOTIMP.
2AFC	WSANO_DATA	Valid name, no data record of requested type.